

**CABINERY DIMENSIONS**  
**E442B,**

**HEIGHT**  
**175cm**  
 (min 174)

**WIDTH**  
**72cm**

**DOORS**  
**7.0cm D**

**DEPTH**  
**62.5cm**

AIR  
 VENTILATION  
 DUCTING

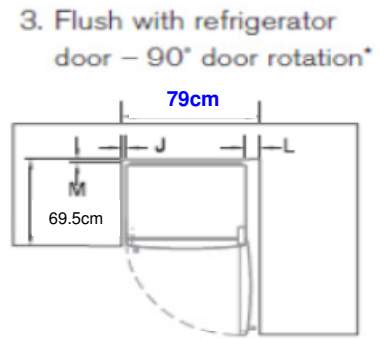
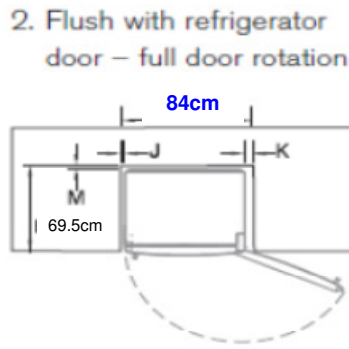
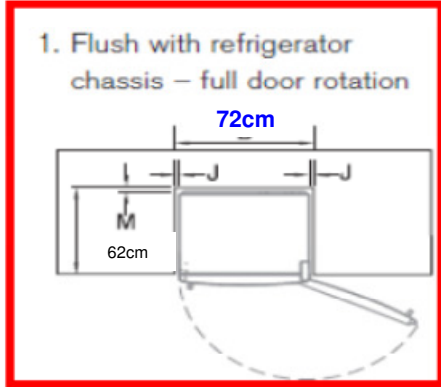

**E442BRXFDU4**



**E442BRXFD4**



**Refrigerator**

EZKleen Stainless Steel flat door  
 Designer with Designer handle

**Capacity:** 296 litres (10.41 cu.ft) Refrigerator \*\* 295 lt Refrigerator (with I&W)  
 100 litres (3.43 cu.ft) Freezer \*\* 97 lt Freezer (With I&W)  
 396 litres (13.84 cu.ft) Total \*\* 392 lt Total (With I&W)

**Energy rating:** **A+**

**Energy usage:** 175 kW per year / for models I&W 380kW per year

**Noise level:** 43dB

**Performance:** Active Smart™ system, Frost free freezer, Adaptive defrost, Humidity control system, Humidity control lid, Sabbath mode

**Refrigerator:** Water dispenser, Door alarm, 4 Adjustable glass shelves, Bottle rack, 2 Full width adjustable door shelves, 2 Half width adjustable door shelves, 2 Covered door shelves, 2 Egg trays, Halogen light

**Freezer:** Built-in ice maker, 1 Large plastic bin, 2 Small plastic bins, Ice bin and scoop, 1 Centre roll out tray, Door alarm

**Accessories:** Water filter (part number 836848)

**For I&W Models use HALF INCH TAP**

**REFRIGERATOR DIMENSIONS:**

**H 171.5cm X W 68.0cm X D 69.5cm**

\*DEPTH: 62.5cm + 7.0cm (DOORS)

1) EXCLUDING HANDLES

2) INCLUDING EVAPORATOR (BACK)