

FALMEC BUILT/IN HOOD

Model: GRUPPO INCASSO PRO



FEATURES

- Scotch Brite Inox finish
- **Dynamic LED** Lighting
- Removable & Washable
- metallic grease filter,
Charcoal filter optional
- Oil Collector
- Baffle filter

TECHNICAL FEATURES

- Installation Type: **BUILT/IN**
- Motor: **950m₃/h**
- Electronic Control
- **4 Speed Settings**
- **4 x 1,2w LED** Lighting
- Energy Class: **A**
- Maximum Consumption: **320W**

MOTOR TECHNICAL SHEET

EU DIRECTIVE SETTING 3

- Maximum Capacity: **860m₃/h**
- Noise level: **64dB(A)**
- Pressure (PA): **620Pa**
- Motor Power: **240W**

15cm EXTRACTION HOLE
(preferable plastic piping to reduce noise level)

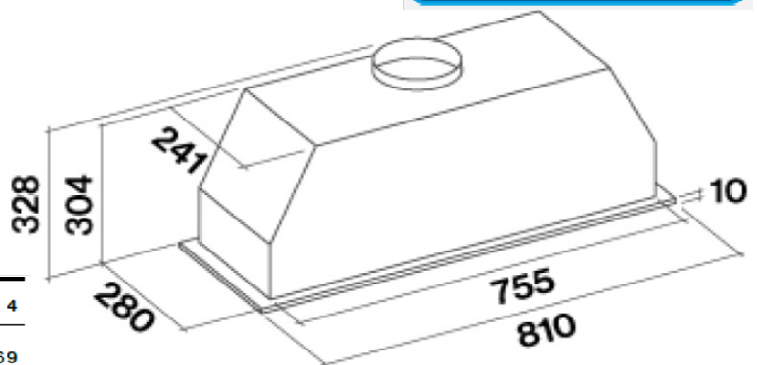
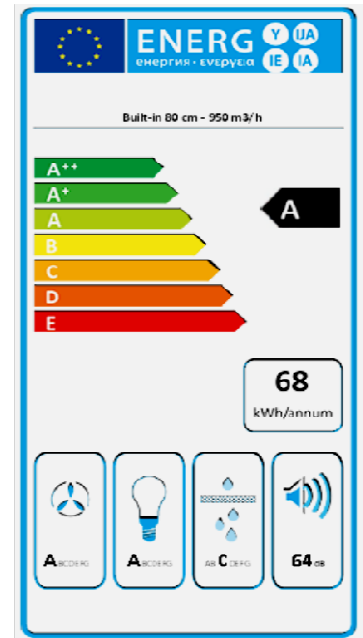

Cut-Out size: 755 x 280 mm

Speed motor	1	2	3	4
Noise dB(A)re1pW-I.E.C.60704-2-13	53	58	64	69
Capacity (m ³ /h) I.E.C.61591 Tubazioni normalizzate	350	470	620	860
Maximum pressure (Pa)	500	540	560	600
Power motor (W)	185	215	240	260
Air outlet	150	150	150	150