

Freestanding Range Cooker, Dual Fuel, 90cm, 5 Burners

Series 7 | Contemporary

Stainless Steel



Get the best of both worlds with dual fuel. A gas hob with wok burner is paired with a convection oven with 9 functions.

- Five burner hob with with dual wok burner and two powerful triple ring burners
- Convection oven with 140L total capacity and nine oven functions including Pastry Bake with pizza mode
- Non-tip full-extension shelves for safe removal of hot dishes

DIMENSIONS

Height	898 - 946 mm
Width	897 mm
Depth	600 mm

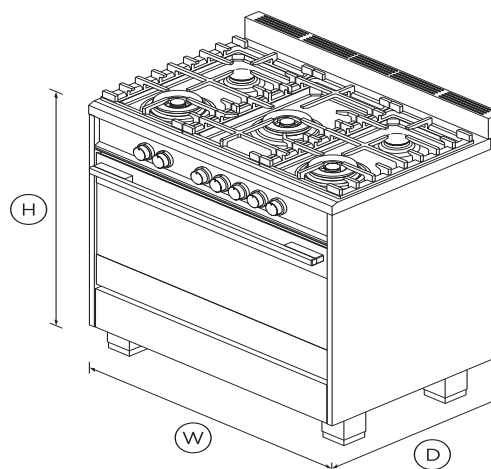

FEATURES & BENEFITS

Multi-shelf cooking

Our AeroTech™ system circulates air evenly throughout the entire oven so dishes on the top shelf turn out just as perfect as food cooking on the bottom shelf.

Quality and durability

Every detail has been carefully crafted. The solid, perfectly balanced soft-close door, precise electric temperature control and chromed cast zinc dials all add up to an exceptional, premium range.

Burner power & control

Instant and immediate control from the highest to the gentlest heat. The finely tuned hob controls let you sear, stir fry or simmer a delicate sauce to perfection.

Easy to clean

Cleaning up spills is effortless. Your hob simply needs a quick wipe to keep it looking good as new. The pyrolytic self-clean oven cycle breaks down food residue at a very high temperature, leaving a light ash that's easily removed with a damp cloth.

Even heat

Accurate, electronically-controlled oven heat ensures a great result every time.

Large capacity oven

The generous 140L total capacity oven gives you plenty of space to cook multiple dishes at once.

SPECIFICATIONS

Accessories

Chromed shelf runners	1 set
Flat wire shelf	•
Full extension sliding shelves	1 set (part 578744)
Grill rack	•
Kick strip, stainless steel	Part 81661
Roasting dish	•
Small pot support	1 (part 533981 cast)
Step down wire shelf	•
Wok stand	1 (part 534678)

Capacity

Shelf positions	6
Total capacity	140L

Usable capacity **121L**

Cleaning

- Acid resistant graphite enamel •
- Drop down grill element •
- Removable oven door •
- Removable oven door inner •
- Removable shelf runners •

Consumption

Energy rating **A**

Controls

- Audio feedback •
- Automatic cooking/minute •
- Automatic pre-set •
- Celsius/Fahrenheit •
- Electronic clock •
- Interior light •
- Laser etched graphics •
- Precise electronic temperature •
- Sabbath mode •
- Turned stainless steel clock •
- Turned stainless steel dials •

Main oven features

Capacity total **140L**
 Capacity usable **120L**
 Shelf positions **6**

Oven features

- AeroTech™ technology •
- Automatic rapid pre-heat •
- Electronic oven control •
- Full extension telescopic **1 set (part 578744)**
- Internal light **4 x 25W halogen (2 side & 2)**
- Soft open/close door •
- Storage drawer •
- True convection •
- Twin cavity fans •

Oven functions

- Bake •
- Classic bake •
- Energy slow cook •
- Fan bake •
- Fan forced •
- Fan grill •
- Grill •
- Number of functions **9**
- Pastry Bake with Pizza mode •
- Roast •

Oven performance

CoolTouch door **Quadruple glazed**
 Grill power **4500W**

Power requirements

Amperage **22A**

Supply frequency **50Hz**
 Supply voltage **220 - 240V**

Product dimensions

Depth **600 mm**
 Height **898 - 946 mm**
 Installation cutout dimensions **600 mm**
 Installation cutout dimensions **900 mm**
 Width **897 mm**

Hob Features

- Dishwasher safe trivets •
- Hob rear trim **60mm**
- LPG/Natural gas compatible •
- Sealed range top •

Hob Performance

Dual wok burner inner/outer **0.3 - 4.5kW**
 Dual wok burner inner/outer **0.4 - 4.5kW**
 Max burner power **4.5kW**
 Number of burner elements **5**
 Number of burners **5**
 Semi-rapid burner (LPG) x2 **0.45 - 1.2kW**
 Semi-rapid burner (natural) **0.45 - 1.2kW**
 Total cooktop power **14.9kW**
 Triple ring wok burner (LPG) **1.8 - 4kW**
 Triple ring wok burner (natural) **1.8 - 4kW**

Safety

- Advanced cooling system •

Anti-tilt bracket	•
Balanced oven door	•
CoolTouch door	•
Flame failure system	•
Full extension telescopic	•
Non-tip shelves	•
Spill containment	2.6L

Warranty

Parts and labour	5 years
------------------	----------------

SKU	81723
-----	-------

TEST The product dimensions and specifications in this page apply to the specific product and model. Under our policy of continuous improvement, these dimensions and specifications may change at any time. You should therefore check with Fisher & Paykel's Customer Care Centre to ensure this page correctly describes the model currently available. ? Fisher & Paykel Appliances Ltd 2020

Other product downloads available at fisherpaykel.com

- [↓](#) User Guide
- [↓](#) Service & Warranty Booklet
- [↓](#) Installation Guide
- [↓](#) Installation Guide (KICK-STRIP ATTACHMENT)



A PEACE OF MIND SALE

24 Hours 7 Days a Week Customer Support

T 08000 886 605 Wwww.fisherpaykel.com