

Model: CEILING 90 IX

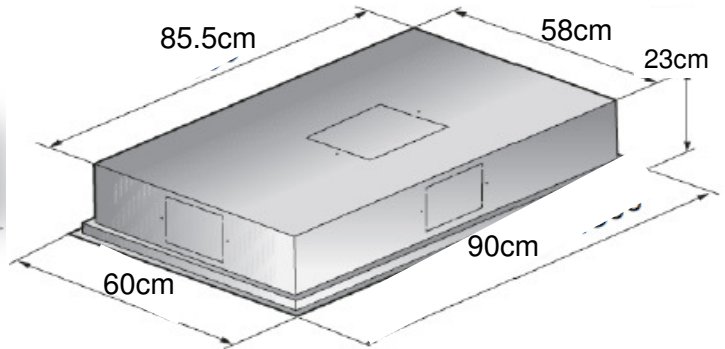

CEILING

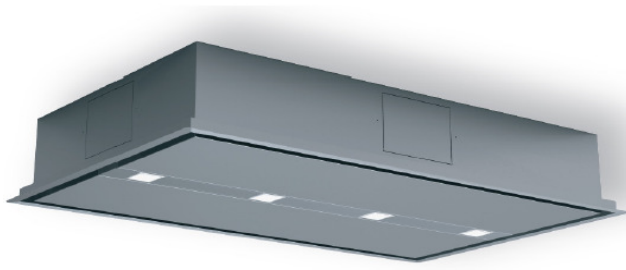

90cm X 60cm



INOX



3 x Halogen Lights



ALUMINIUM PANEL



EXTRACTION HOLE 15cm Ø



DUCTING PIPE 15cm Ø



REMOTE CONTROL



DUCT OUT



HIGH



703 m³/h



430 - 436 PA



I: 53-57



II: 63-67



250W W

Extraction systems

Detachable Motor Capability

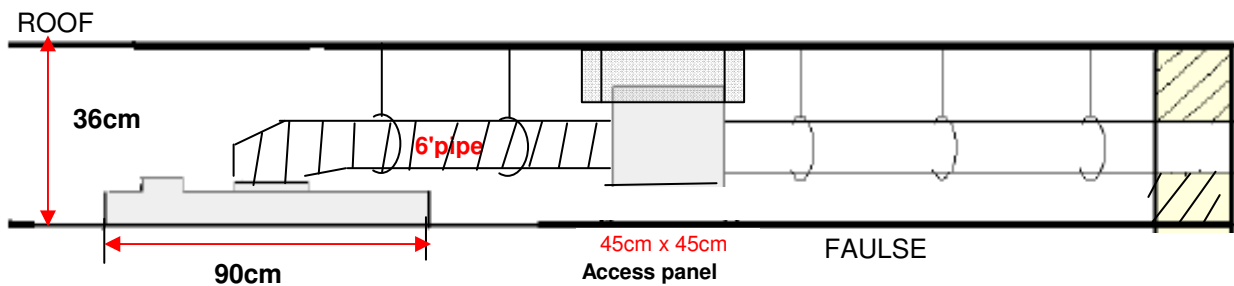

1. Remote Motor: 700m³/h

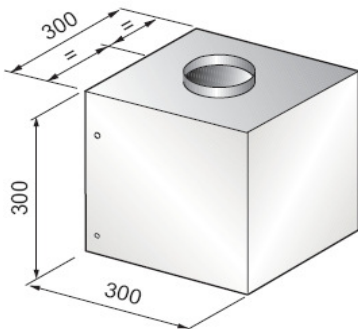

3. External Motor: 500m³/h

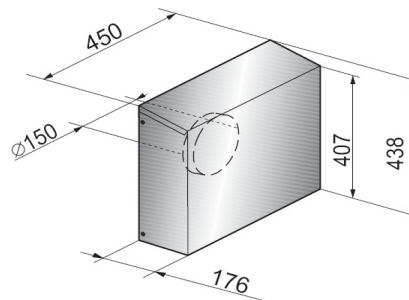

ΣΗΜΑΝΤΙΚΟΝ:

Η ΤΡΥΠΑ ΚΟΠΗΣ ΣΤΗΝ ΓΥΦΟΣΑΝΙΔΑ, ΘΑ ΠΡΕΠΕΙ ΝΑ ΕΝΙΣΧΥΕΤΑΙ ΠΕΡΙΜΕΤΡΙΚΑ ΜΕ ΕΙΔΙΚΗ ΣΙΔΕΡΕΝΙΑ ΛΑΜΑ ΓΥΦΟΣΑΝΙΔΑΣ.