

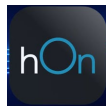

### Key Features

- Capacity (number of seats): **14**
- Energy efficiency class **C**
- **Wi-Fi & Bluetooth** Conn. With **hOn**
- Width (mm): **598**



### Specifications

- Capacity (number of seats): **14**
- Number of programs: **8**
- Maximum time delay start (h): **1-23h**
- Functions Delay start
- End of cycle indicator: **With buzzer**
- Salt light indicator
- Number of wash temperatures: **8**
- Quick 59" cycle
- **Automatic Door Opening**
- Drying system: **Condenser**
- Adjustable upper basket
- Drying efficiency class: A**
- Noise level dB (A): **46**
- Water consumption (liters): **9,5**
- Total energy cons. Per 100cycles (kWh): **74**

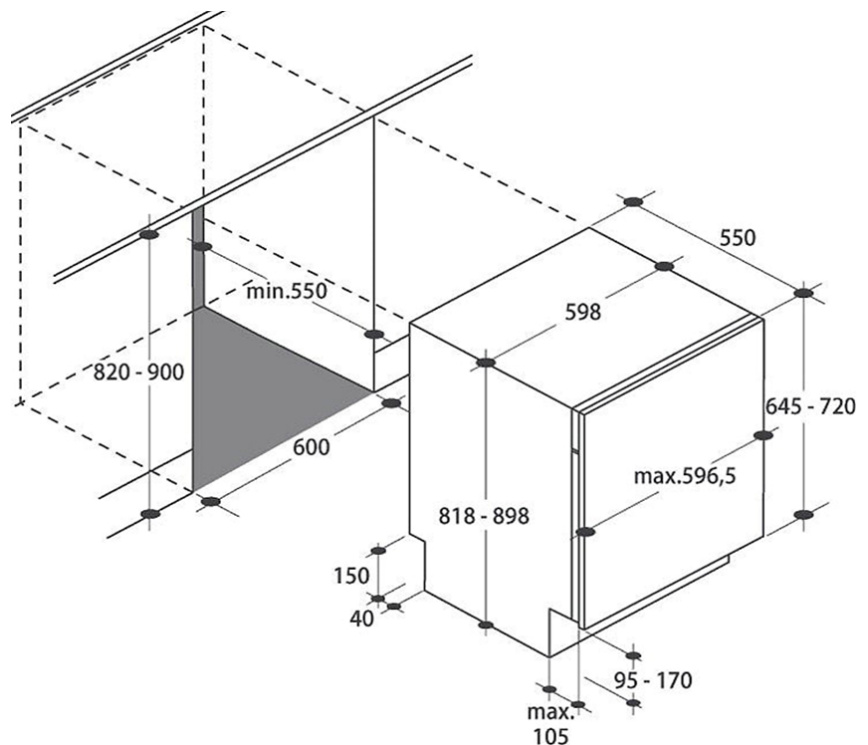

### Dimensions

- Gross Weight (kg): **35.40**
- Depth (mm): **550**
- Width (mm): **598**
- Height without worktop (mm): **820**

