

FISHER & PAYKEL HOBS

MODEL:CE754DTB1

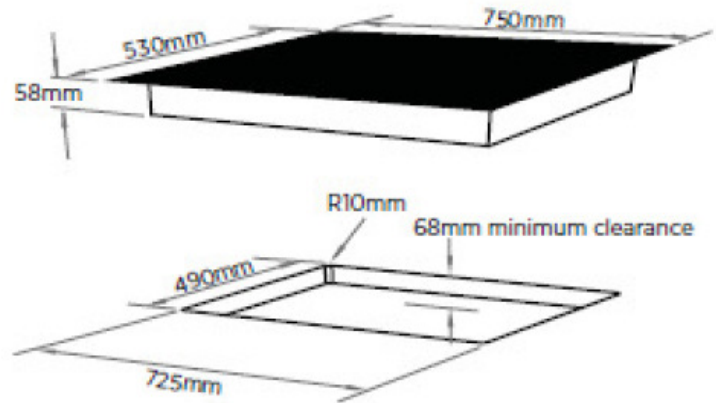
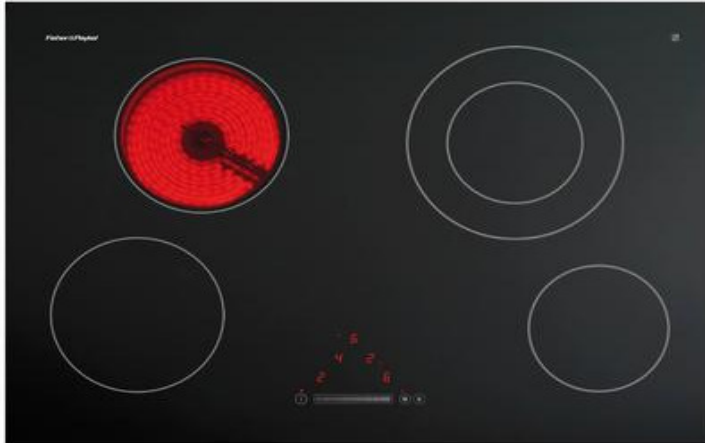

Type of appliance

Model no.

Finish

Dimensions

Elements

Element ratings

Left front

Right front

Left rear

Right rear

GentleHeat

Performance

Hi-light high speed ribbon elements

Dual element

Auto heat reduce

Cleaning

Flat easy clean glass surface

Safety

Key lock

Safety time out

Individual hot surface indicators

Temperature limiters

Spillage auto off

Controls

Touch&Slide controls

Minute timer

Auto cut-off timer for each element

75cm 4 Element Electric Cooktop

CE754DTB1

Ceramic glass

H58 x W750 x D530mm

4 including 1 dual element

1800W

1200W

1200W

2500W/1100W

20W

