

FALMEC BUILT-IN HOOD

Model: GRUPPO INCASSO 70



FEATURES

- Scotch Brite Inox finish
- Peripheral Aspiration
- **Dynamic LED** Lighting
- Removable & Washable metallic grease filter,
- Charcoal filter optional

TECHNICAL FEATURES

- Installation Type: **BUILT/IN**
- Motor: **800m₃/h**
- Electronic Control
- **4 Speed Settings**
- **2 x 1,2w LED** Lighting
- Energy Class: **B**
- Maximum Consumption: **215W**

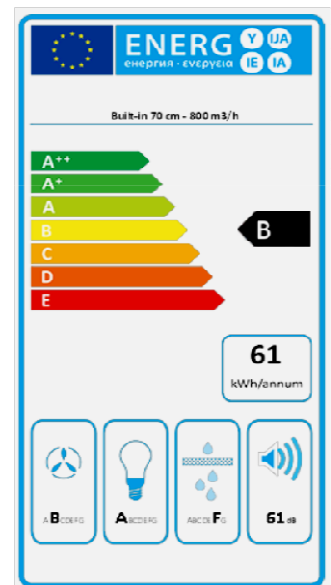

MOTOR TECHNICAL SHEET

EU DIRECTIVE SETTING 3

- Maximum Capacity: **670m₃/h**
- Noise level: **61dB(A)**
- Pressure (Pa): **460Pa**
- Motor Power: **180W**

15cm EXTRACTION HOLE
(preferable plastic piping to reduce noise level)

Speed motor	1	2	3	4
Noise dB(A) _{re1pW-1.E.C.60704-2-13}	49	55	61	67
Capacity (m ³ /h) I.E.C.61591 Tubazioni normalizzate	270	360	470	670
Maximum pressure (Pa)	390	420	460	500
Power motor (W)	134	156	180	215
Air outlet	150	150	150	150

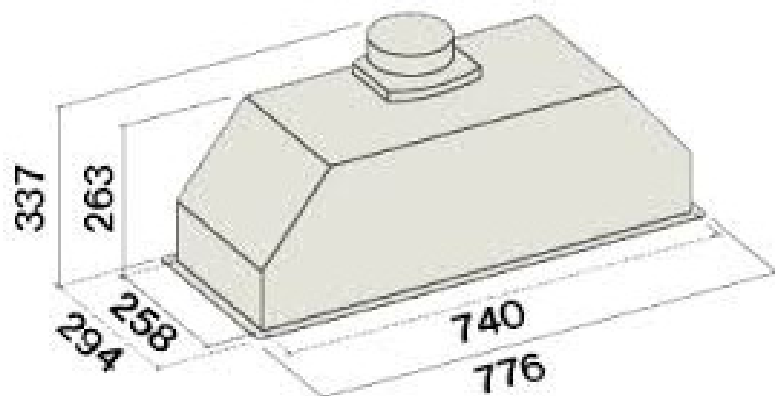

Cut-Out size: 755 x 265 mm