

## FALMEC BUILT/IN HOOD

Model: GRUPPO INCASSO 50



### FEATURES

- Scotch Brite Inox finish
- Peripheral Aspiration
- **Dynamic LED** Lighting
- Removable & Washable metallic grease filter,
- Charcoal filter optional

### TECHNICAL FEATURES

- Installation Type: **BUILT/IN**
- Motor: **800m<sub>3</sub>/h**
- Electronic Control
- **4 Speed Settings**
- **2 x 1,2w LED** Lighting
- Energy Class: **B**
- Maximum Consumption: **215W**

### MOTOR TECHNICAL SHEET

#### EU DIRECTIVE SETTING 3

- Maximum Capacity: **670m<sub>3</sub>/h**
- Noise level: **61dB(A)**
- Pressure (Pa): **460Pa**
- Motor Power: **180W**

**15cm EXTRACTION HOLE**  
(preferable plastic piping to reduce noise level)

Speed motor	1	2	3	4
Noise dB(A) <sub>re1pW-I.E.C.60704-2-13</sub>	49	55	61	67
Capacity (m <sup>3</sup> /h) I.E.C.61591 Tubazioni normalizzate	270	360	470	670
Maximum pressure (Pa)	390	420	460	500
Power motor (W)	134	156	180	215
Air outlet	150	150	150	150

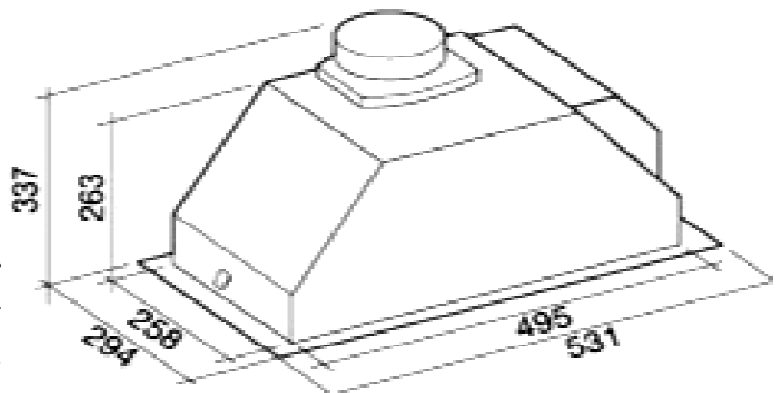
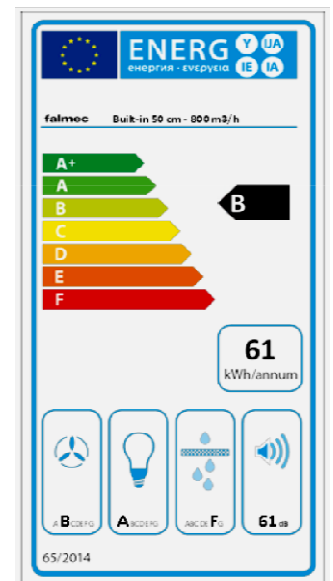

**Cut-Out size: 505 x 265 mm**