



### **Configuration**

- Adjustable shelves 3
- Clear freezer bins 2
- Adjustable door shelves
- 

### **Performance Features**

- ActiveSmart Foodcare
- Door open alarm
- Fast freezer
- Frost Free
- Holiday controlled crisper bins
- LED lighting
- Rapid cooling
- Variable temperature drawer

### **Dimensions**

- Depth 606mm
- Height 2028mm
- Width 906mm
- Freezer Volume 102L
- Refrigerator Volume 329L
- Total gross volume 431L

### **Consumption Data**

- Energy Rating A+
- Inverter controlled compressor

- Automatic Ice Maker
- Bottle Chill
- Ice Boost
- Ice Bin & Scoop
- Adaptive Defrost
- Deli Storage Bins

### **Design**

- Bottom mount freezer
- Door opening (Left or Right hand opening)

### ③ PRODUCT AND CAVITY DIMENSIONS

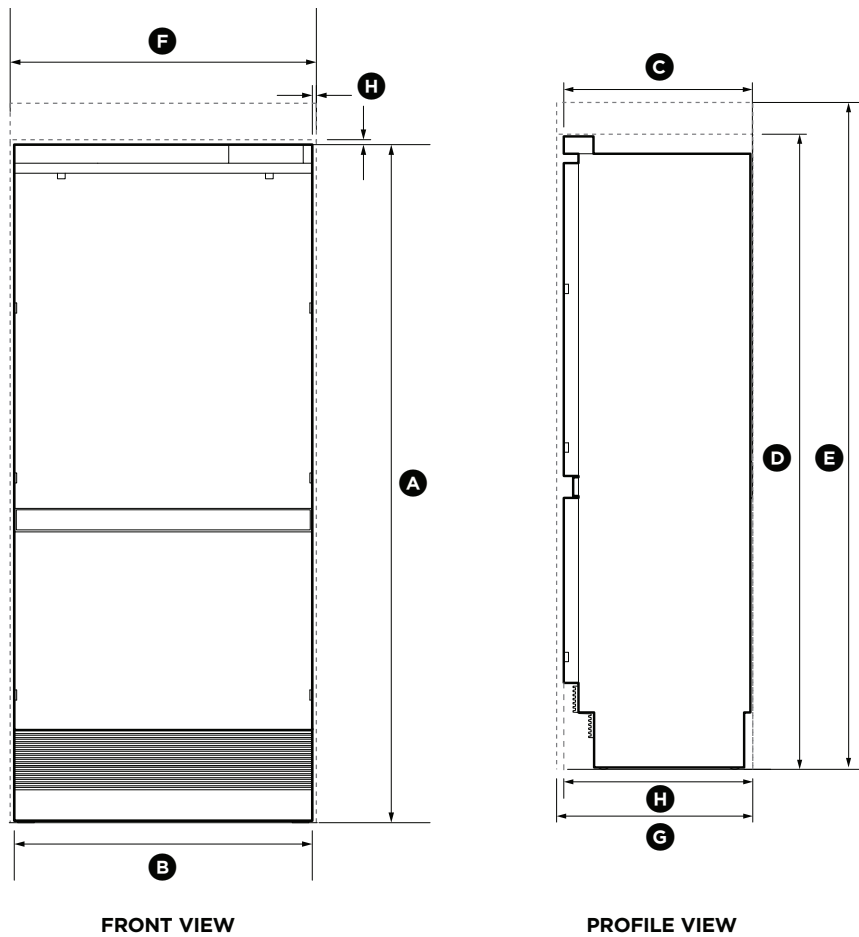

PRODUCT DIMENSIONS	mm
Ⓐ Overall height of product*	2130
Ⓑ Overall width of product	906
Ⓒ Overall depth of product (without door panels)	606

\* Includes mounted feet

#### IMPORTANT!

For ease of installation, ensure cavity width is consistent top to bottom and height is consistent left to right.

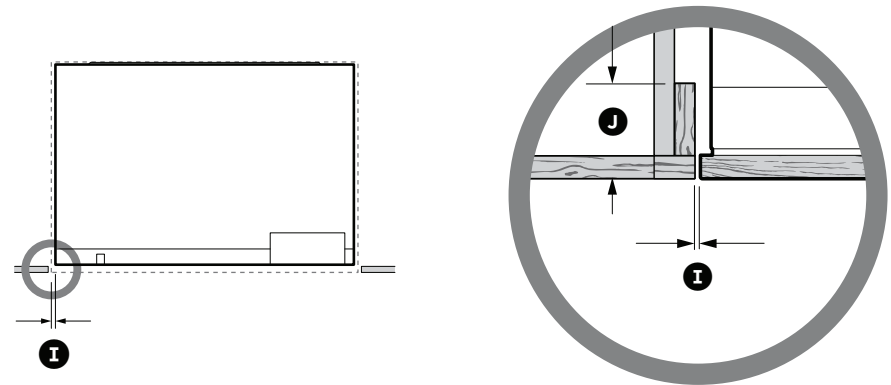

PLAN VIEW

Note: image shows custom panel flushed with edge of cabinetry

CAVITY DIMENSIONS	mm
Ⓓ Overall height of cavity (for refrigerator using RD9120 door panel set)**	2032
Ⓔ Overall height of cavity (for refrigerator using RD9121 door panel set)**	2134
Ⓕ Overall width of cavity	914
Ⓖ Overall depth of cavity (for flush installation)	635
Ⓗ Overall depth of cavity (for proud installation)	629
Ⓘ Minimum cabinetry gap clearance from edge of product	4
⓵ Minimum required finished return (side and top cavity)	min. 127

\*\* Supplied top trim enables cavity height to be either 2032mm or 2134mm.

\*\*\* Assumes a door panel thickness of 19mm.

For integrated installation, ensure finished return dimensions are as shown.