

# FISHER & PAYKEL 60cm INTERGRATED REFRIGERATOR

## MODEL: RB60V18



### ***Made to Measure***

- The Fisher & Paykel 60cm Integrated Fridge is designed to intergrade seamlessly behind cabinetry, freeing up your kitchen design possibilities and allowing you to create a kitchen that suits your lifestyle

### ***Seamless Fit***

- This is the fridge for people who want to hide their fridge behind cabinetry - you can't see where one starts and the other stops. The 60cm Integrated Fridge is designed to allow only the smallest gaps between cabinetry meaning smooth lines and perfect symmetry.

### ***Design Flexibility***

- Left and right options give you the freedom to put the fridge where you like and dress it to suit the style of your kitchen. Place one by itself, or pair two together, even add a CoolDrawer to make the most of your distributed food care and design options

### ***Easy Cleaning***

- The Fridge is fitted to retain spills, making clean up easier. The shelves can be repositioned at different heights to accommodate different sized food storage containers. The clear shelves mean you can easily find what you're looking for while being able to easily keep them fresh and clean.

### ***Variable Temperature Drawer***

- The Variable Temperature Drawer is designed to allow optimal storage of fresh meat, deli and dairy products at lower than standard fridge temperatures. Simply adjust the temperature anywhere between -5°C and 3°C to suit the food in your Variable Temperature Drawer

### ***Fruit and Vegetable bin***

- The fruit and vegetable bin has a humidity control slide that can be adjusted to fruit or vegetable setting depending on what is being stored in the bins. The humidity mat is designed to hold your fruit and vegetables off the base of the bin allowing increased airflow around your produce, extending the life of your food.

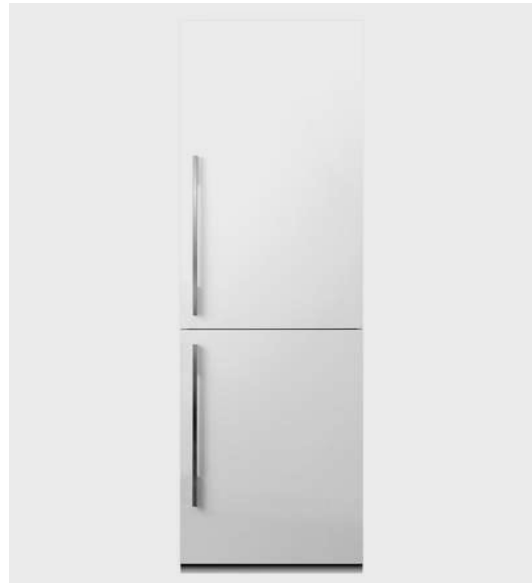

**Configuration**

- Adjustable shelves
- Clear freezer bins        3
- Egg Trays                    1
- Three shelves (incl. above vegetable area)

**Consumption Data**

- Energy Rating A++
- Energy Usage (kWh/yr) 237

**Performance Features**

- Automatic defrost
- Door open alarm
- Fast freezer
- Frost Free
- Holiday controlled crisper bins
- LED lighting
- Rapid cooling
- Variable temperature drawer

**Design**

- Bottom mount freezer
- Door opening (Left or Right hand opening)

**Dimensions**

- Depth - door closed not including handle        540mm
- Freezer Volume                    80 litres
- Height - incl. feet and hinge cap    1773mm
- Refrigerator Volume                186 litres
- Total gross volume                266 litres
- Total net volume                    225 litres
- Width                                555mm

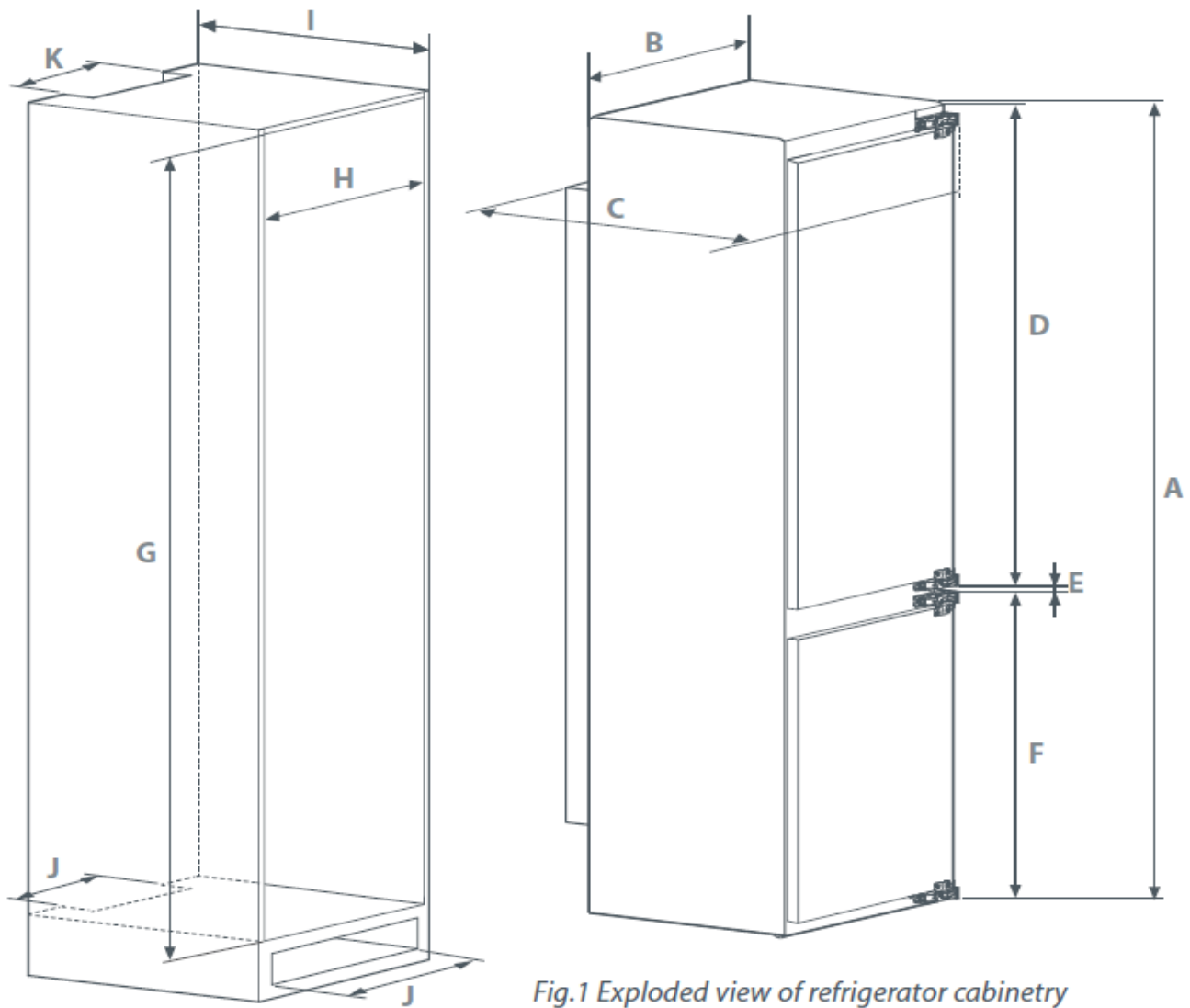

Fig.1 Exploded view of refrigerator cabinetry

Product dimensions (mm)	RB60V18
A total height	1773
B total width	555
C total depth	540
D top door height	1066
E hinge gap height	12
F bottom door height	692
Cabinetry dimensions (mm) (including minimum clearances)	
G inside height	1782 – 1786
H inside width	564 – 570
I total depth	min 550
Minimum clearances	
J minimum inlet vent area	200 cm sq
K minimum outlet vent area	280 cm sq