

CABINERY DIMENSIONS

**E402B
E411T**

**HEIGHT
175cm**

**WIDTH
68cm**

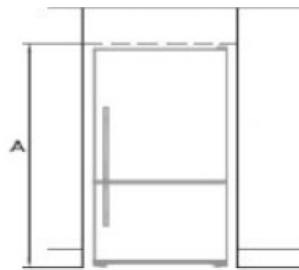

**DOORS
7.0cm D**

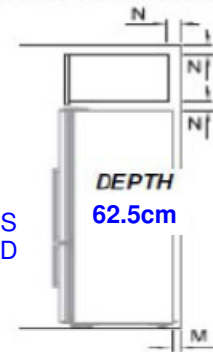

**AIR
VENTILATION
DUCTING
3cm
3cm**

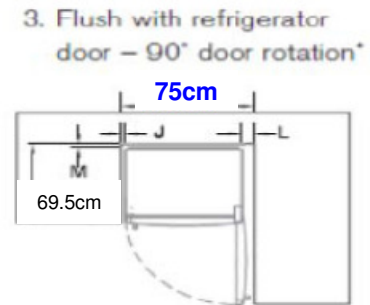
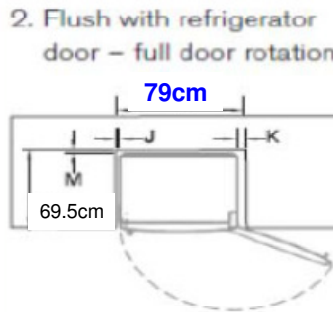
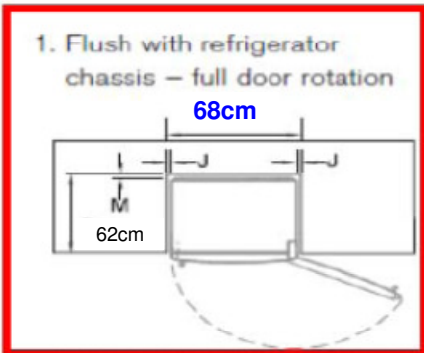

E402BRXFD4



E402BRXFDU4



Refrigerator

EZKleen Stainless Steel flat door
 Designer with Designer handle

Energy rating: A+

Energy usage: 335 kW per year / for models I&W 340kW per year

Noise level: 42dB

Performance: Active Smart™ system, Frost free freezer, Adaptive defrost, Humidity control system, Humidity control lid, Sabbath mode

Refrigerator: Water dispenser, Door alarm, 4 Adjustable glass shelves, Bottle rack, 2 Full width adjustable door shelves, 2 Half width adjustable door shelves, 2 Covered door shelves, 2 Egg trays, Halogen light

Freezer: Built-in ice maker, 1 Large plastic bin, 2 Small plastic bins, Ice bin and scoop, 1 Centre roll out tray, Door alarm

Accessories: Water filter (part number 836848)

Capacity 273 litres (9.61 cu.ft) Refrigerator ** 272 lt Refrigerator (with I&W)
 91 litres (3.11 cu.ft) Freezer ** 88 lt Freezer (With I&W)
 364 litres (12.72 cu.ft) Total ** 360 lt Total (With I&W)

REFRIGERATOR DIMENSIONS:

H 171.5cm X W 63.5cm X D 69.5cm

*DEPTH: 62.5cm + 7.0cm (DOORS)
 1) EXCLUDING HANDLES
 2) INCLUDING EVAPORATOR (BACK)